

參考用

1. Determine the reactions at the beam support A for the given loading, as shown in Fig. 1. (25%)
2. Draw the shear force and bending-moment diagrams for the beam AB (as shown in Fig. 2) and determine the maximum absolute values of the shear force and bending moment. (25%)
3. As shown in Fig. 3, if the coefficient of static friction at all contacting surfaces is μ_s , determine the inclination θ at which the identical blocks, each of weight W , begin to slide. (25%)
4. As shown in Fig. 4, determine the internal normal force, shear force, and bending moment at point C in the beam. (25%)

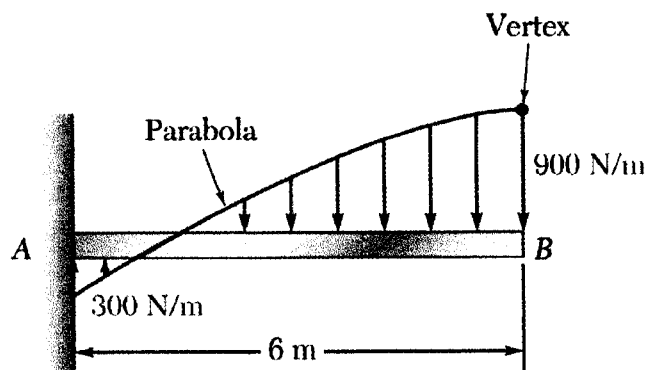

Fig. 1

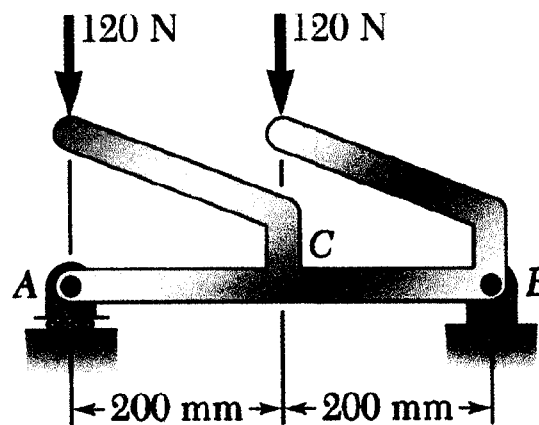

Fig. 2

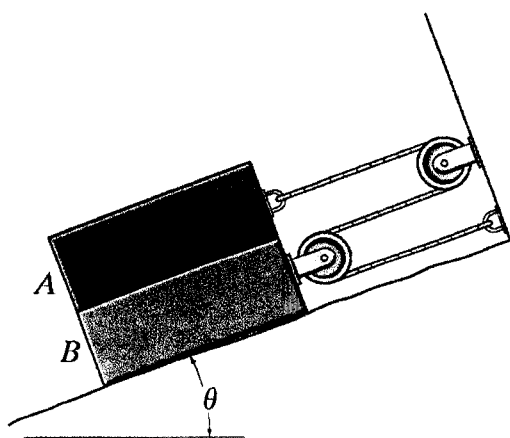

Fig. 3

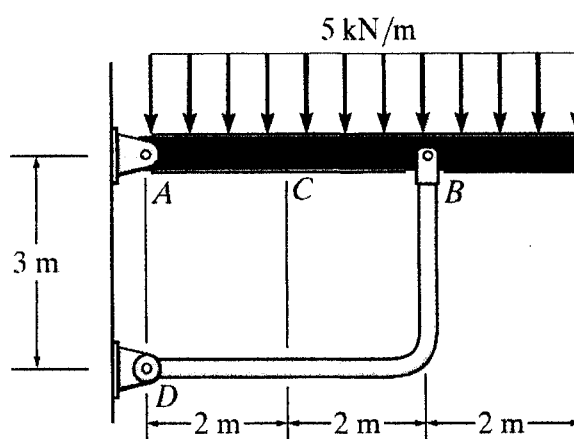

Fig. 4