

# 國立中央大學九十學年度碩士班研究生入學試題卷

所別: 光電科學研究所 不分組 科目: 普通物理 共 1 頁 第 1 頁

1. (15%) A laser has a power of 5 W and a beam diameter of 2.5 mm. If it is aimed vertically upward, what is the height  $H$  of a perfectly reflecting cylinder that can be made to "hover" by the radiation pressure exerted by the beam? Assume that the density of the cylinder is  $1.5 \text{ g/cm}^3$ . (see Fig. 1)
2. (15%) Consider the circuit of Fig. 2. The curved segments are arcs of circles of radii  $a$  and  $b$ . The straight segments are along the radii. Find the magnetic field  $B$  at  $P$ , assuming a current  $i$  in the circuit.
3. (15%) A spherical sound source is placed at  $P_1$  near a reflecting wall  $AB$  and a microphone is located at  $P_2$ , as shown in Fig. 3. The frequency of the sound source is variable. Find the two lowest frequencies for which the sound intensity, as observed at  $P_2$ , will be a maximum. There is no phase change on the reflection; the angle of incidence equals the angle of reflection. The sound wave velocity is  $340 \text{ m/s}$ .
4. (15%) An RC circuit is discharged at  $t=0$ . The initial potential difference across the capacity is  $100 \text{ V}$ . If the potential difference has decreased to  $1 \text{ V}$  after  $10 \text{ s}$ , (a) calculate the time constant of the circuit. (b) What will be the potential difference at  $t=15 \text{ s}$ ?
5. (20%) A full power of  $1.5 \text{ MW}$  railroad locomotive accelerates a train from a speed of  $10$  to  $25 \text{ m/s}$  in  $6 \text{ min}$ . (a) Neglecting friction, calculate the mass of the train. (b) Find the speed of the train as a function of time in seconds during the interval. (c) Find the force accelerating the train as a function of time during the interval. (d) Find the distance moved by the train during the interval.
6. 簡答題 (20%)
  - (1) 解釋何謂“兩道光波互為 coherent”? (5%)
  - (2) 請舉出三項日光燈管與氣體雷射管所產生的光之差異性，並簡述其原理? (6%)
  - (3) 我們將雷射光調成許多短脈衝在長距離之光纖內傳輸，該脈衝的分佈帶有我們欲傳輸的資訊，請舉出三種使得我們無法在接收端接受到清楚訊號的可能因素(在無外力干擾下)。 (9%)

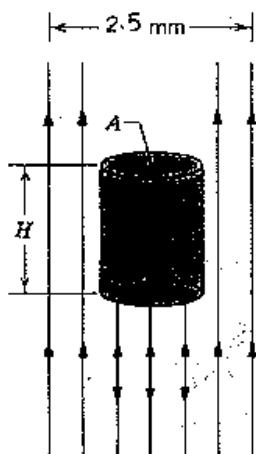

Fig. 1

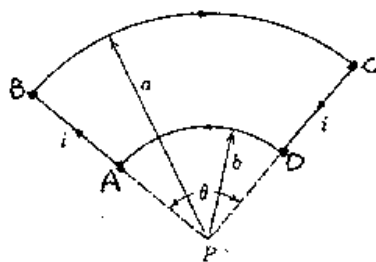

Fig. 2

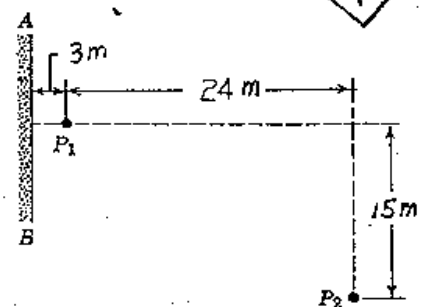

Fig. 3

請勿翻閱